



PERGAMON

Energy Conversion & Management 41 (2000) 1293–1301

ENERGY
CONVERSION &
MANAGEMENT

www.elsevier.com/locate/enconman

Use of PV systems in remote car filling stations

G.E. Ahmad*, M.A. Mohamad

Solar Energy Department, National Research Centre, El-Tahrir St, Dokki, Cairo, Egypt

Received 23 April 1999; accepted 29 October 1999

Abstract

In Egypt, the average daily solar energy incident on a horizontal surface exceeds 5 kWh/m²/day and, also, there are many remote areas that are not covered by the electrical energy of the grid utility. So it was necessary to depend on solar energy in supplying these remote applications. This paper introduces a case study for designing a PV system for feeding a remote area car filling station to be operated using photovoltaic energy. The design parameters will depend mainly on the load energy needed by the station, the geographical site data (solar radiation, ambient temperature) and, also, the degree of availability of electrical energy needed for the system.

To ensure the PV system availability and reliability during its operation, an expectation for the system performance is prepared. The expected monthly average daily output energy from the PV system is compared with that needed by the load during a complete year. In the case of rural zones, it is proven that the economic situation of the photovoltaic system will be competitive, especially in a site of high availability of solar energy, like the remote areas of Egypt. © 2000 Elsevier Science Ltd. All rights reserved.

Keywords: Photovoltaic energy; System design; Remote areas

1. Introduction

Nowadays, photovoltaic energy is widely used as an alternative source of energy for many remote applications. It is used in communications, water pumping, solar homes and in grid connected systems.

* Corresponding author. Fax: +202-33-709-31.

E-mail address: elazaly@hotmail.com (G.E. Ahmad).

In Egypt, there are many projects that were set-up in rural areas in recent years. Also, new roads were established to connect these rural areas under consideration and the main cities. From this point of view, it is intended in this paper to submit a suggested design of a photovoltaic power system for feeding a car filling station on these roads. This design can be generalised to be installed on all remote roads taking into consideration the changes of the site specifications and load requirements and its effects on the design.

In spite of the low initial cost of diesel generators in operating these types of stations, they are not preferred because they have many drawbacks. Diesel generators need continuous maintenance and have a reduced life time. Also, they always need fuel that may be expensive. They cause noise and increase pollution in the environment. From another point of view, PV systems may have high initial cost, but in rural regions they are economically competitive with diesel generators, as will be shown in this paper.

In the case of stand alone systems, the load is supplied only by the photovoltaic energy generated from the PV panels. A typical stand alone photovoltaic system incorporates a solar array, battery bank, power conditioning unit, system control and the load. Fig. 1 shows a block diagram for a typical stand alone PV power system [1,2].

2. The station's PV system sizing

There are a wide variety of methods for sizing PV systems with a highly reliable load coverage. In this case study, it is required to size a PV system to meet the energy requirements of a typical car filling station on one of the desert roads. The PV system sizing for this situation can be determined according to the following procedures.

2.1. The load components and energy requirements

The car filling station that is required to be energized by a PV generator is expected to

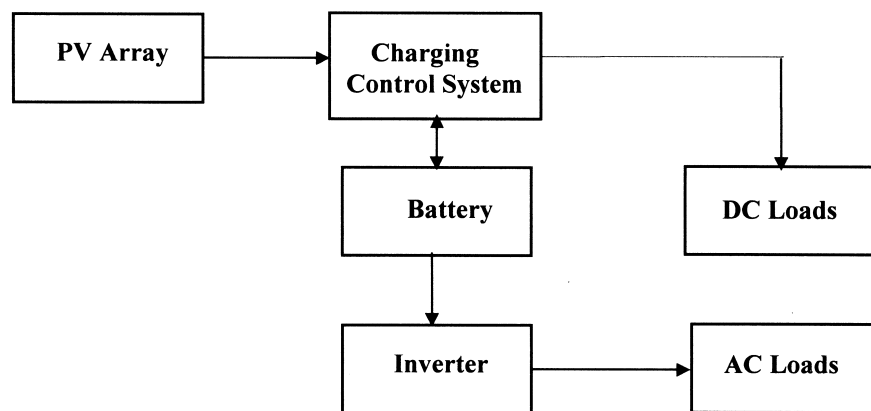

Fig. 1. A block diagram for a typical stand alone PV power system.

contain the loads indicated in Table 1. The load components and their ratings and times of operation are selected according to the data obtained from a car filling station at the end of Cairo and located near the desert road.

Fig. 2 introduces an evaluation of the load profile per day of a car filling station in different seasons taking into consideration that the load profile in autumn is the same as that of spring. It is noticed from Fig. 2 that the expected daily load energy requirements (shaded area) in winter, spring, summer and autumn are 21.3, 22, 25.5 and 22 kWh/day, respectively. The average daily load energy requirements/year can be calculated from the different season load profiles to be 22.7 kWh/m²/day.

2.2. Site specifications

To plan for any PV system project, it is very important to get detailed information about the weather conditions. The data of the incident solar energy on a horizontal surface, on an inclined surface with an inclination angle equal to the latitude (ϕ) of the site and, also, the average ambient air temperature are very important for a good PV system design. In this design the data of solar energy input on the inclined surface and the average ambient temperature for Cairo will be used. Fig. 3 gives the required site environmental data for the design [3,4].

It is clear in Fig. 3 that the mean ambient temperature for Cairo reaches 30°C in the summer. Accordingly, the surface temperature of PV panels is expected to be higher than 60°C. In the winter the mean ambient temperature decreases, giving lower PV surface temperatures. Also, the lowest daily solar energy incident on a tilted surface with an angle equal to the latitude angle (Φ) is found to be 4.17 kWh/m²/day in December, while the largest value for that energy incident on the tilted surface is found to be about 6.84 kWh/m²/day in August. The yearly average value is calculated to be 5.88 kWh/m²/day.

2.3. Sizing of PV array

Sizing of the PV array depends mainly on the load energy demand, the site specifications and the efficiency of the other components in the PV system, such as the battery and inverter efficiencies. Eq. (1) can be used to give the required size of PV array suitable for feeding the station with the required energy [2] as follows:

Table 1
The load components and their electrical power ratings

Load type	No. of units	Load power (kW/unit)
Benzene pumps	2	0.5625
Kerosene pumps	2	0.5625
Water pumps	1	0.75
Lighting	8	0.04
Elec. fans	2	0.05
Refrigerator	1	0.3

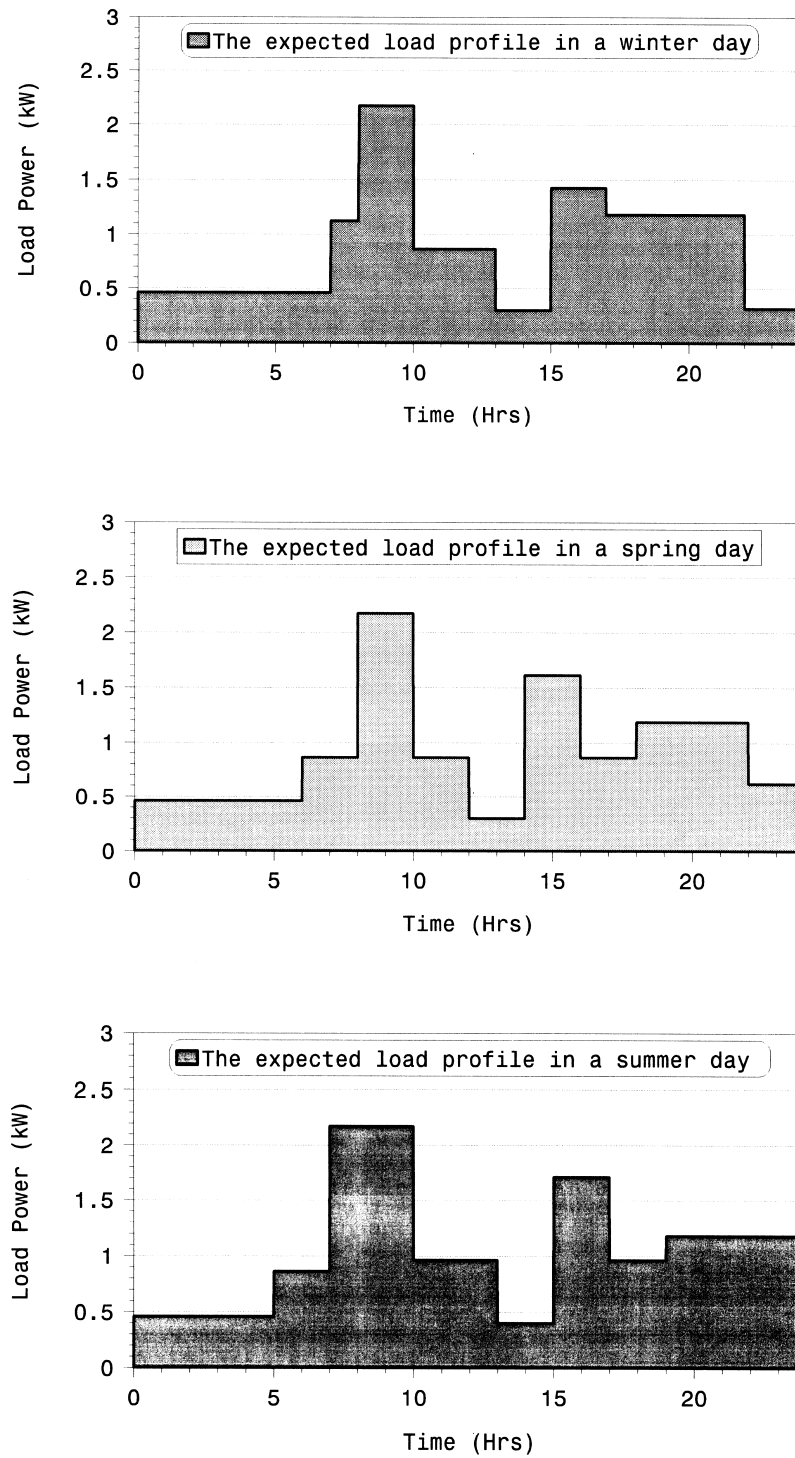

Fig. 2. The expected daily load profile during winter, spring and summer.

$$\text{Size of PV array} = \frac{(\text{PPR}/\text{SE})(\text{ED}/H)}{\eta_b \times \eta_{\text{inv}}} \quad (1)$$

where PPR = PV power rating in kW/m², SE = the system operating efficiency, (ED/H) = the ratio between the energy demand and the average daily irradiation in the plane of the array, η_b = the effective battery efficiency and η_{inv} = the inverter efficiency.

In this case study, the system sizing factor (PPR/SE) is considered to be about 1.25 to take the effect of panel surface temperature (exceeds 60°C in Cairo during the summer) and wiring losses into consideration. The average daily energy demand (ED) is considered to be 22.7 kWh/day while the average irradiation (H) collected on the tilted PV array at an angle = ϕ is found to be 5.88 kWh/m²/day. Finally, assuming that the effective battery efficiency is about 0.8 and the inverter efficiency is 0.9, Eq. (1) can be applied to determine the suitable size of the PV array as follows:

$$\text{Size of PV array} = \frac{1.25 \times (22.7/5.88)}{0.8 \times 0.9} = 6.7 \text{ kW}$$

2.4. Sizing of storage batteries

The required capacity of storage batteries can be calculated according to the following relation [5]:

$$\text{Battery storage} = \frac{N_c \times \text{ED}}{\text{DOD} \times \eta_b \times \eta_{\text{inv}}} \quad (2)$$

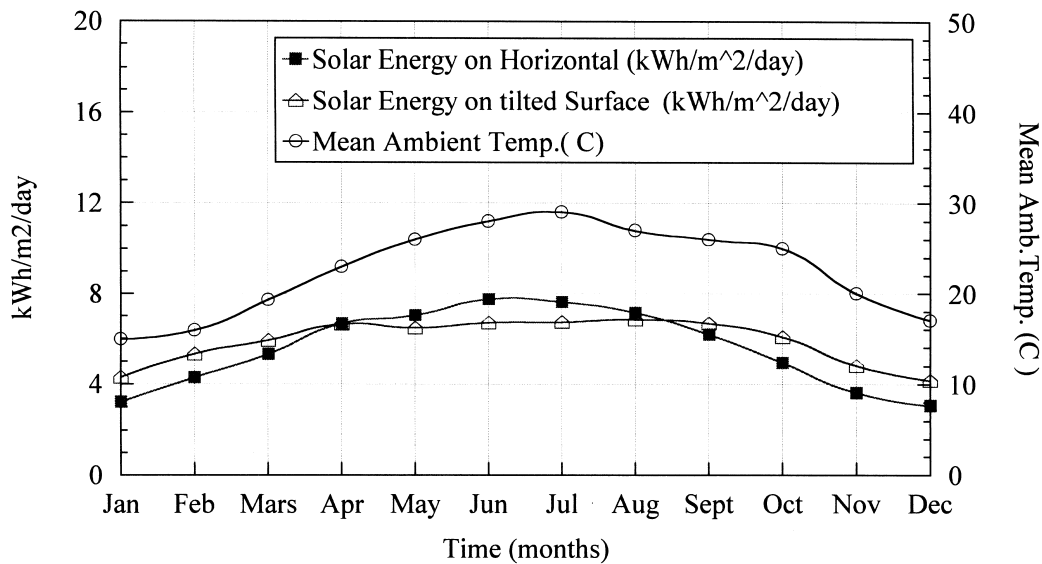

Fig. 3. The solar energy on horizontal and tilted surfaces and the mean ambient temperature for Cairo during a complete year.

where DOD = the allowable depth of discharge for the batteries, ED = the daily energy demand (kWh/day), N_c = number of continuous cloudy days, η_b = battery efficiency and η_{inv} = inverter efficiency.

The number of continuous cloudy days in Cairo can be considered to be 3 days and the allowable depth of discharge for the batteries is taken to be 80%. Thus, ED = 22.7 kWh/day, N_c = 3 days, DOD = 0.8, η_b = 0.8, η_{inv} = 0.9 and battery storage = $(3 \times 22.7) / (0.8 \times 0.8 \times 0.9) = 118.2$ kWh

Choosing a 24 V system, the required ampere hours of batteries = $(118.2 \times 1000) / 24 \cong 4925$ Ah. Choosing batteries of 12 V, 500 Ah, the number of batteries required = $2 \times 4925 / 500 \cong 20$ batteries. Thus, 20 batteries are needed, each of 12 V, 500 Ah.

2.5. The control system

To prevent the batteries from night discharge into the PV array, a suitable blocking diode must be inserted between the array and the batteries [6]. Also, to protect the batteries against overcharging or deep discharging, it is important to use a suitable voltage regulator in the PV system. There are different types of regulators that can perform this job with PV systems. Shunt regulators can be used with small PV systems, while series regulators are used with larger systems.

2.6. The inverter

The inverter is used with PV systems that are used to feed ac loads. In this case study, it is expected to use only ac loads. The inverter can be chosen 10% higher than the rated power of the maximum expected ac loads, thus, using Table 1:

The maximum ac loads power (kW)

$$\begin{aligned} &= (2 \times 0.5625) + (2 \times 0.5625) + (1 \times 0.75) + (8 \times 0.04) + (2 \times 0.05) + (1 \times 0.3) \\ &= 3.72 \text{ kW} \end{aligned}$$

The inverter rated power = $3.72 + (0.1 \times 3.72) \cong 4.1$ kW

Thus, the inverter can be chosen with the specifications of 4.1 kW, 24 V_{dc} and 220 V_{ac}.

2.7. The expected system performance

To ensure system availability and reliability during its operation, the following equation is used to calculate the PV array average daily output energy during a complete year:

$$\text{The average daily PV system energy output} = P_{\text{peak}} \times F_{dT} \times H_i \times \eta_b \times \eta_{inv} \quad (3)$$

where P_{peak} = the peak power rating of the PV array, F_{dT} = a correction factor for dust accumulation and panel temperature = 0.85 in our case and H_i = the average daily radiation

(kWh/m²/day) on the inclined surface of the PV array at an angle ϕ (corresponds to the daily peak sunshine hours).

Substituting into Eq. (3) with the corresponding values in our case study, Fig. 4 gives the calculated expected photovoltaic system energy output during a complete year and also the energy required by the load during the same period. It is also noticed that the energy required by the load is slightly higher than that produced by the PV system during the months of January, November and December.

2.8. PV system economics

It is noticed in recent years that the efficiency of solar cells is increasing. This is due to the use of new techniques and new materials. Also, a higher reliability and longer expected life time are achieved (about 25 years life time). In the design example presented in this paper, it is noticed that mainly four components are used to feed the rural service station. These components are the PV array, storage batteries, BVR and dc/ac inverter. All the components are expected to operate for 25 years with few problems and low maintenance, except for the batteries which need regular maintenance and may be changed a total of three times during the 25 years of operation.

The expected price of this system can be estimated as the summation of the prices of its components, taking into consideration that the batteries will be changed 3 times during the 25 years of expected operation for the system and that the annual cost of maintenance and operation is about 2% of the total system cost.

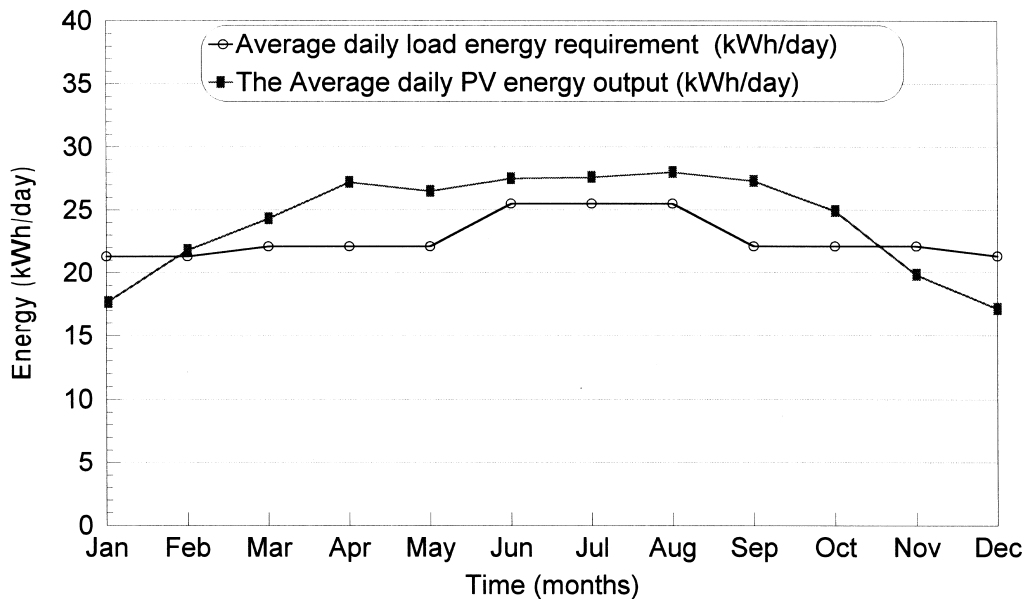

Fig. 4. The expected monthly average daily photovoltaic system energy output and load energy demand versus time of year.

Total system price according to the prices in Egypt in 1999 = price of PV array + (3 × price of battery × No. of batteries) + price of inverter + price of BVR (6.7 kW × 25000 E.L./kW) + (3 × 750 E.L. × 20) + 10000 E.L. + 3000 E.L.

Total PV system price = 225500 E.L. (≅ US\$66324) (E.L. = Egyptian pounds) (US\$1 = 3.4 E.L.).

Assuming that the annual cost of maintenance and operation is about 2% of the total system cost:

The cost of maintenance and operation = $0.02 \times 225500 \times 25 = 112750$ E.L. (= US\$33162).

The total system cost during 25 years = $225500 + 112750 = 338250$ E.L. (= US\$99486).

If it is assumed that the average daily load demand will be about 22.7 kWh/day on the average estimation, then:

the average output energy from the system in 25 years = $25 \times 365 \times 22.7$ (= 207138 kWh).

price/kWh = $(338250/207138) = 1.6$ E.L./kWh (= US\$0.48/kWh).

2.9. The equivalent diesel generator system cost

- Two diesel generators, each of 10 kVA operating 12 h (10000 E.L./unit).
- 20% of the initial price every 4 years for replacement.
- 3% of the initial price for annual maintenance and oil changing.
- The fuel cost during 25 years (20 l benzene/day, i.e. 20 E.L./day) according to the present price and considering that the annual increase in the fuel cost is about 3%.

The total diesel generator system cost =

initial price + (20% of the initial price × 6 times replacement)

+ (3% of the initial price for annual maintenance and oil changing)

$$+ \sum_{n=1}^{n=25} [(\text{first year fuel cost})(1.03)^{n-1}].$$

The total diesel generator system cost =

$$(2 \times 10000) + (0.2 \times 20000 \times 6) + (0.03 \times 20000 \times 25) + \sum_{n=1}^{n=25} [(20 \times 365)(1.03)^{n-1}]$$

$$= 325154 \text{ E.L. (= US\$95634).}$$

Price/kWh = $325153/207138 = 1.57$ E.L./kWh (= US\$0.462/kWh).

The price of the produced energy using PV systems may be seen to be slightly higher than that produced using an equivalent diesel generator. Fig. 5 introduces the total cost of the PV system and that of the diesel generator during their lifetime (25 years). It can be said that the difference in the price between the two systems is very small with respect to the benefits of the

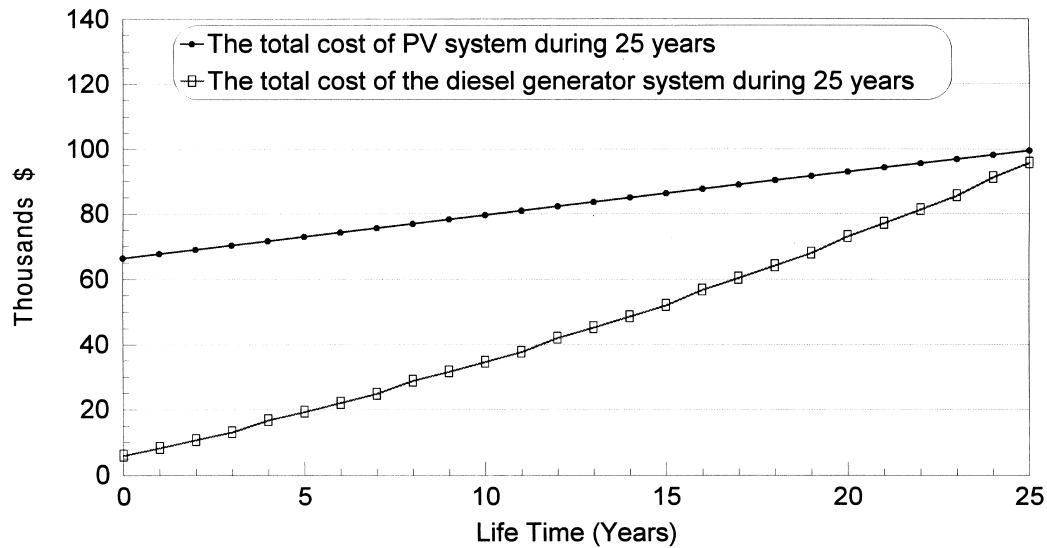

Fig. 5. The total cost of the PV system and that of the diesel generator during their life time.

PV system over the diesel generator system as described in Section 1. Also, the prices of PV panels are decreasing with time.

3. Conclusions

From this work one can say that PV stand alone systems can be used in many applications for remote areas, especially in developing countries that have many areas not covered by the grid utility. Also the use of PV systems in these applications is very competitive with diesel generators and can lead to developing these remote areas and maintaining a clean environment.

References

- [1] Groumpos PP, Papageorgiou G. An optimal sizing method for stand-alone photovoltaic power systems. *Solar Energy* 1987;38(5):341–51.
- [2] Lasnier F, Gan Ang T. In: Hilger A, editor. *Photovoltaic Engineering Handbook*. Bristol and New York: IOP Publishing, 1990.
- [3] Mosalam Shaltout MA. Solar energy input to Egypt, Bulletin No. 271. Helwan Institute of Astronomy and Physics, Academy of Scientific Research and Technology, Egypt, August 1981.
- [4] Mohamad MA. Impacts of some technical factors and meteorological and operational conditions on PV generator size for water pumping. *Energy Sources* 1992;14:73–80.
- [5] Wenham SR, Green MA, Watt ME. *Applied Photovoltaics*. Centre for Photovoltaic Devices and Systems, 1994.
- [6] Green MA. *Solar Cells Operating Principles, Technology and System Applications*. Englewood Cliffs, NJ: Prentice-Hall, 1982.