

Optimization of Supervisory Control Strategy for Parallel Hybrid Vehicle with Provisional Load Estimate

Ivan Arsie, Marco Graziosi, Cesare Pianese, Gianfranco Rizzo, Marco Sorrentino

Department of Mechanical Engineering - University of Salerno

Contact Address: Fisciano (SA), 84084, ITALY Phone: 0039.089.96.4069, Fax: 0039.089.96.4037
Email: pianese@unisa.it

The paper focuses on the simulation, analysis and control of the energy flow in a parallel hybrid electric vehicle (HEV). HEVs operation is concerned with the on board conversion of chemical, electric and mechanic energy and its optimal control is essential in order to increase the global system efficiency.

A dynamic model is used to describe the driver-vehicle interaction for a generic transient and to simulate the vehicle driveline, the internal combustion engine (ICE) and the electric motor/generator (EM). An estimate of future vehicle load is performed with a neural network to optimize the supervisory control strategy during the estimated future time window.

A description of the whole model is presented and the simulation results carried out for a real driving cycle are reported.

Topics / Electric & Hybrid Vehicles, Powertrain Control and Management, Modeling and Simulation.

INTRODUCTION

In the last years the increasing interest for energetic and environmental problems has given a strong impulse toward the development of alternative propulsion systems for automotive applications. The hybrid electric vehicles (HEVs) seem to be a good and feasible solution from energetic-environmental as well as industrial point of view. They are equipped with an electrical traction system, composed of a set of batteries and an electric motor/generator (EM) which is coupled with a standard internal combustion engine (ICE). Thus, HEVs present all the advantages of the electric traction (e.g. limited pollution and acoustic impact, significant energy saving, and improved drivability) together with the typical features of ICE such as high autonomy (Riley, 1994; Hochgraf et al. 1996; Powell et al., 1998; Nagasaka et al., 1998; Baumann et al., 1998; Guzzella and Amstutz, 1999).

Depending on the powertrain layout, two different HEVs configurations can be considered: series hybrid vehicles and parallel hybrid vehicles. In the series HEV, the ICE powers an electric generator for recharging the battery pack and the vehicle is powered by an electric motor. In the parallel architecture, both ICE and EM are mechanically coupled to the transmission and can simultaneously power the vehicle. This configuration offers a major flexibility to different working conditions (i.e. driving cycle).

The dynamic model designed for simulating the on-board energy flow (i.e. mechanical, chemical, electrical) during arbitrary driving cycles, accounts for the following working modes (Arsie et al., 2002-I):

- [1] Electric mode: the vehicle is powered by the EM while the ICE is switched off.
- [2] Hybrid mode: the EM works as motor and assists the ICE in powering the vehicle.
- [3] Recharging mode: the ICE powers the EM which works as electric generator to charge the battery pack.
- [4] Regenerative braking: during vehicle deceleration the EM works as a generator to charge the battery pack, thus converting the vehicle kinetic energy into electrical energy.

In the model, the above modes are selected according to the control strategy selected through a Dynamic Programming procedure to minimize the fuel consumption. The optimization is performed starting from a provisional drive load estimate performed with a Time Delay Neural Network based dynamic model.

In the following the powertrain model, the energy control strategy and its optimization procedure are described. In the results section, the simulation related to a real driving schedule are presented and discussed.

SYSTEM CONFIGURATION

The powertrain of the parallel hybrid vehicle considered for the present study is sketched in Figure 1: the powertrain has a spark-ignition IC engine (4 cylinders, 16 valves, 1242 cm³, 65 kW) and an electric asynchronous three-phase motor/generator (30 kW); a lead-acid battery package is used for the electric energy storage. A cogged belt connects the thermal engine and the electric motor and an electromagnetic clutch decouples the engine from the drivetrain. In order to

focus the attention on the energy flow control strategy and to reduce the computational effort, the driveline has been simulated as a rigid body neglecting torsional elasticity and clutch dynamics (Arsie et al., 2000).

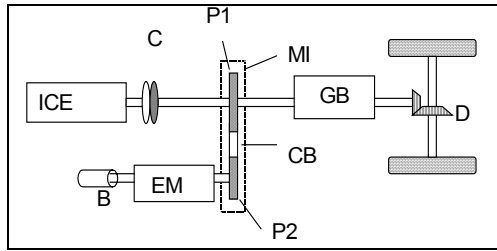

Figure 1 - Parallel hybrid vehicle powertrain - ICE=Thermal Engine; C= Electromagnetic Clutch; P1, P2=Pulleys; MI=Mechanical Interface; GB= Gear Box or Continuous Variable Transmission (CVT); D= Differential Gear; CB=Cogged Belt; EM=Electric Motor; B=Battery.

MODEL DESCRIPTION

In order to simulate the hybrid vehicle during a generic driving mission, the developed model describes the main powertrain components and simulates the driver behaviour in following the velocity target. A block diagram of the complete system is sketched in Figure 2 where all the main physical sub-models, the control tasks and the mechanical torque paths are shown.

The Driver Behaviour (DB) model is based on the fuzzy logic and provides the actual gas pedal position in following the target velocity profile of the vehicle. In the proposed vehicle model, the control of the longitudinal dynamics is performed adopting a fuzzy logic controller (Babuška, 1998). The pedal position and its derivative are used as input for the Driver Interpreter block (DI), which estimates the load demand (traction or braking torque) to meet the driver intention. The Driver Interpreter output is split into a torque demand for the ICE and the EM by the supervisory controller (VMU).

A throttle controller is implemented (TC) to provide the effective throttle opening position as function of the ICE load demand, which is evaluated by the VMU. The throttle opening is assumed as input for the ICE model to simulate the engine behaviour.

The effective power delivered by the electric machine (EM) is estimated from the electric power demand computed by the VMU, accounting for the EM efficiency stored into a look-up table.

The power provided by both the EM and the ICE is used as input for the driveline model (DL) to compute the actual rotational speed of EM and ICE and the vehicle speed.

During the battery recharging the mechanical torque to the generator is supplied by the ICE (recharging mode) or by the DL (regenerative braking mode), then the battery state of charge (SOC) is updated. In the following sections a description of each block is provided.

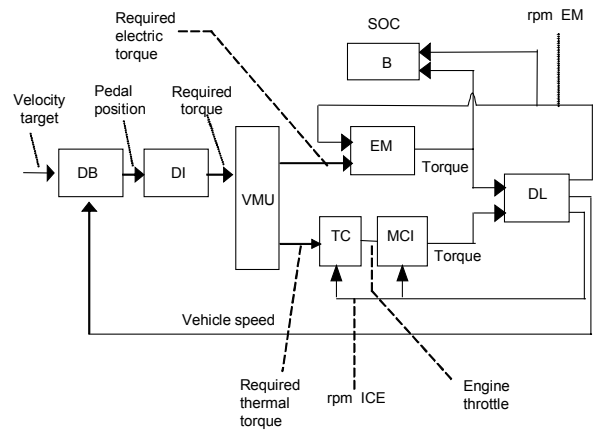

Figure 2 - Block diagram of the parallel hybrid vehicle model with the driver sub-model (DB): DI=Driver Interpreter; VMU=Vehicle Management Unit; TC=Throttle Controller; ICE=Thermal Engine; EM=Electric Motor; DL=Driveline; B=Batteries.

INTERNAL COMBUSTION ENGINE MODEL

The Internal Combustion Engine (ICE) model is derived from the model O.D.E.C.S., which was developed by the authors for the optimal design of engine control strategies in spark ignition engines (Arsie et al., 2000). It is based on two different modelling approaches, depending on the goals and the phenomena to be studied. The first class of models is a set of black box (steady state neural networks) which provide the engine torque and the exhaust emissions as function of engine state (manifold pressure and engine speed) and control variables (injection time, spark advance). This approach is useful for the control strategy design and optimization, for which the recursive evaluation of a cost function is required.

The second engine modelling approach is used to describe the dynamic effects of the air-fuel flow into the intake manifold and is based on a filling-emptying mean value model, neglecting the unsteady fluctuations due to periodic phenomena.

ELECTRIC MACHINE MODEL (EM)

In a parallel hybrid vehicle the electric machine can work as a motor or as a generator depending on the actual working mode (i.e. electric, hybrid or recharging) (Baumann et al., 1998; Burch et al., 1999; Arsie et al., 2002-I).

In order to reduce the computational effort, the behavior of the electric machine is modeled through a 2-D look-up table of the efficiency, which is expressed as function of the required torque and the motor/generator rotational speed (Guzzella and Amstutz, 1999). The efficiency map has been derived from literature data and refers to an asynchronous motor with a rated power of 30 [kW] at 9000 rpm. The same efficiency has been assumed, for both motor and generator working modes. Depending on the working mode, the electrical power P_{EM} is given by the following equations (Guzzella and Amstutz, 1999):

$$P_{EM} = T_{EM} \omega_{EM} \eta(\omega_{EM}, T_{EM}) \quad (1)$$

$$P_{EM} = \frac{T_{EM} \omega_{EM}}{\eta(\omega_{EM}, T_{EM})} \quad (2)$$

Equation (1) holds in case of recharging mode when the EM works as generator and charges the battery pack by an electric power P_{EM} , while equation (2) is applied for electric and hybrid working modes. In these latter conditions, the EM works as electric motor and is powered by the battery pack which is depleted with an electric power P_{EM} . T_{EM} is the torque provided by the EM as required by the VMU controller and can be either negative or positive depending on the EM working mode.

DRIVELINE (DL)

The driveline model describes the rotational dynamics of ICE, electric motor, transmission, final drive and wheels. It is composed by a one state dynamic system, neglecting the clutch dynamics during gearshift, the torsional shaft deformation and the tire elasticity. The driveline is modelled making use of the Newton's law, reducing all the load torque and the momentum inertia to the crankshaft; the aerodynamic losses and the tire rolling friction have been considered as resistant torque. Thus, the driveline dynamics is described by the following differential equation:

$$I \frac{d\omega}{dt} = T_{ICE} + T_{EM} - T_{Res} \quad (3)$$

where I is the equivalent inertia of the powertrain-vehicle system, T_{ICE} , T_{EM} and T_{Res} are the ICE torque, the EM torque and the resistant torque, respectively. In case of electric or hybrid working mode, the EM works as a motor and powers the driveline ($T_{EM} > 0$). On the other hand, in case of recharging mode, the EM works as generator and T_{EM} is considered as a load torque ($T_{EM} < 0$).

BATTERY'S MODEL (B)

The Battery package (B) (see Figure 2) has been simulated using the ESS block (Energy Storage System) derived from the ADVISOR simulator (Burck et al., 1999). This block models the batteries taking into account the basic electrochemical processes including heat exchange phenomena as well. The computational block provides the battery state of charge (SOC), the actual current and other variables such as the current thermal state as function of the actual electrical power (i.e. positive or negative). The actual current is computed starting from the electrical power, making use of the Kirchhoff's voltage law. For a complete description of the battery model the reader is addressed to the original work of Burch et al. (1999). The battery pack is composed by a set of 30 modules of valve-regulated lead-acid (VRLA) 12 V batteries.

CONTROL STRATEGY

In the hybrid vehicle the main control task is performed by the Vehicle Management Unit (VMU), a

supervisor unit which defines the ratio between the energy supplied by the thermal engine and the energy supplied by the batteries. According to this ratio one of the working modes (Electric, Hybrid, Recharging) is activated, except for the regenerative braking mode which is actuated during the braking manoeuvre. The objective of the supervisor controller is to split the power between the energy systems to achieve the minimum fuel consumption. To accomplish such an objective, several control strategies can be implemented according to various control techniques and different design procedures. Moreover these strategies can either be static (Arsie et al., 2002-I) or dynamic.

The on-line optimization of the energy flows splitting between thermal engine and batteries is performed via dynamic programming technique. This methodology allows to compute the sequence of control actions (i.e. the power splitting) over a time horizon as function of the vehicle load. When the vehicle load schedule is known in advance a global optimum solution would be obtained off-line. Thus the time sequence of the control variables can be stored on the VMU and applied during the scheduled vehicle manoeuvre. When the vehicle is used during different schedule the optimality of the control sequence is not guaranteed. On the other hand if the vehicle schedule is unknown, which is the majority of the real applications, a global optimum technique is therefore not feasible unless a prediction of the vehicle load is available. Thus the dynamic programming global optimum control solution is strictly related to the correctness of the vehicle load schedule prediction. Then the prediction of the vehicle load must be performed to supply the load schedule to the dynamic programming algorithm to find the control variable sequence that minimize the fuel consumption over the predicted time horizon. However, a fully predictive model cannot be built easily since a direct approach would involve the knowledge of several exogenous variables (e.g. driver behaviour) which are not predictable in a deterministic fashion. Nevertheless, a reliable simulation can be performed assuming that a knowledge of the sub-systems involved in the vehicle load evaluation are available or derivable from previous data. Thus a dynamic prediction of the vehicle load can be achieved as function of the previous load states. This approach has been used in the current work to determine a sequence of temporary vehicle load series that is feed to the dynamic programming algorithm to compute on-line the optimal control sequence.

Vehicle load prevision

The temporary vehicle load prediction, assumed in the optimization of the control strategy, is estimated making use of a Recurrent Neural Network (RNN).

In the recent years the Neural Networks have been successfully used as black-box models for the identification and control of nonlinear dynamic systems. Because of their high nonlinear mapping capabilities and good generalization, Neural Networks can easily solve many practical modeling problems. The Recurrent Neural Networks (RNNs) meets this requirement

because of their dynamic properties. The RNNs are derived from the static Multi Layer Perceptron Feed Forward (MLPFF) networks by introducing feedback connections among the neurons. Thus, a dynamic effect is introduced into the computational system by a local memory process. Moreover, by retaining the non-linear mapping features of the MLPFFs, the RNNs are suitable for black-box non-linear dynamic modeling (Patterson, 1995; Haykin, 1999). When the network processes only its delayed outputs the computational structure is called Time Delay Neural Network (TDNN) and the corresponding generic relationship reads as:

$$\hat{y}(t+1) = F[\hat{y}(t|\theta), \hat{y}(t-1|\theta), \dots, \hat{y}(t-n|\theta)] \quad (4)$$

where \hat{y} represents the Network output while θ is the parameters vector of the model whose dimension is function of the number of neurons used. The index n , is the backward time horizon (i.e. the length of the vector containing previous information) and is set according to the complexity of dynamics being simulated. For a detailed description of the RNNs structure and their main implementation issues the reader is addressed to the abounding literature (e.g. Patterson, 1995; Haykin, 1999) and to a previous paper (Arsie et al., 2002-II).

For the present work the network structure is composed of 15 inputs (i.e. the delayed network outputs), 7 neurons in the hidden layer and one output. The parameters network are found making use of an identification procedure based on a real velocity profile (training profile) with a continuous simulation from the start to the end of the schedule. On the other hand during the on-line application a batch simulation is considered by predicting only 20 seconds. The predicted load profile is assumed as the future load in the on-line optimization of the control strategies. At the beginning of each batch the real load profile of the previous 15 seconds is feed to the network in order to restart the simulation for the next 20 seconds with real data. Thus the precision of the prediction decreases as the end of the time horizon is approached. Indeed the last 5 values of the predicted power schedule are function of simulated data only. The time windows of 20 seconds have been selected after a parametric analysis conducted for some real velocity profiles and it has seen as the best compromise between the length of the time windows and the simulation precision.

Dynamic Programming

The Dynamic Programming (DP) is a technique that allows to solve an optimization problem through a sequence of successive decompositions in a multi-stage fashion. The basic theory of this method is based on the principle of optimality formulated by Bellman (1957) who the reader is addressed for a complete description of the technique.

For the purpose of the present application the Dynamic Programming technique has been implemented to find the control law that minimize the overall fuel consumption over a scheduled or estimated power demand of a hybrid vehicle. The DP technique is based on the optimization of the control variable vector

$u(t)$ along the time horizon considered. The optimization is performed after the discretization of the system state variable trajectory along time $[X(t_1), \dots, X(t_n)]$. To apply the DP technique to the hybrid vehicle control, both the mechanical power supplied by the thermal engine and the battery State Of Charge SOC have been chosen as state variables, thus $X(t)=[P_{ICE}(t), SOC(t)]$. Therefore, once the required traction power (P_t) is known the electric motor power is computed as ($P_{EM} = P_t - P_{ICE}$). The power deliverable by the thermal engine is discretized with elementary steps of 1 kW, while the SOC interval considered $[0.65, 0.75]$ is splitted into elementary steps of $4 \cdot 10^{-5}$.

The control variable $u(t)$ is associated with the thermal engine control, influencing directly the output power P_{ICE} at each time step. The control action generates the transition in the states space from the actual state $X(t)$ to the next state $X(t+1)$ according to the relationship $X(t+1)=f(X(t), u(t), t)$; where f is a function related to the powertrain model. A cost is associated with each transition in the states space and is defined as follows:

$$g(X(t), u(t), t) = C_{ICE}(X(t), u(t), t) + p(X(t), u(t), t) \quad (5)$$

where C_{ICE} is the chemical energy used by the thermal engine (i.e. the fuel consumption during the time interval Δt) and the term p is a penalty cost that accounts for the deviation of the SOC from the reference value. In the equation (5) the fuel consumption C_{ICE} is computed as the average value between the actual and the next step values. The penalty term is expressed as $p = \beta(t) \Delta SOC(t)$ with $\Delta SOC(t) = |0.7 - SOC(t)|$ and $\beta(t) = \alpha t$, where α is an heuristic penalty factor chosen as function of the time horizon (Brahma et al., 2000).

The optimal control sequence, $u(t)$ is found by minimizing the functional cost (5):

$$J(X) = \min_{u \in U} \sum_{k=0}^{M-1} g(X(k), u(k), k) \quad (6)$$

where M is the length of the discretized vehicle mission and U represents the constraints imposed on the control variable to satisfy the power demand and to guarantee the power transition between two states. A systematic solution to the above problem can be determined recursively via the backward procedure proposed by Bellman's as follows (Kang et al., 2001):

$$J_{M-1}(X(M-1)) = \min_{u(M-1) \in U(M-1)} [g(X(M-1), u(M-1), M-1)] \quad (7)$$

$$J_k(X(k)) = \min_{u(k) \in U(k)} [g(X(k), u(k), k) + J_{k+1}(f(X(k), u(k), k))] \quad (8)$$

From the equation (7) the algorithm starts to compute the control variable u from the final step, then the previous control sequence is evaluated through the recursive minimization formula (8). The optimal control strategy is any minimizer of (7) and (8). The function $J_k(x(k))$ represents the minimum cost associated to the

transient process in the interval $[k, M-1]$ starting from the state $X(k)$ at the current time step.

RESULTS

The proposed model has been used to simulate the behaviour of a HEV along a real mission profile. The simulated vehicle in its basic configuration weights 1500 kg while an additional mass of 400 kg has been considered for the hybridization. The prediction of the vehicle load during the transient has been performed making use of a Time Delay Neural Network. The training of this Neural Network has been carried out with reference to a different mission profile with respect to that considered for the on-line optimization test. The training velocity profile refers to a mix between urban and suburban drive course for 3600 seconds and the total length is of 22 km. While a shorter (1000 seconds) velocity profile time history has been considered for the optimization test with a route of 6.8 km. This test profile refers to a sequence of suburban and urban courses, shown in the Figure 3, and is characterized by fast acceleration/deceleration transients.

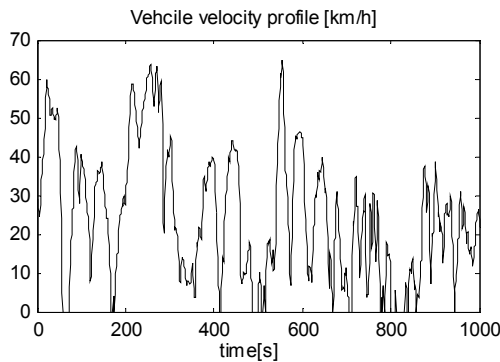

Figure 3 – HEV control strategy test velocity profile.

The Figure 4 and Figure 5 focus on the power control strategy actuated by the optimized VMU. The power splitting between thermal engine and electric motor is reported for suburban and urban areas, respectively. The load power (dotted black line) attains either positive or negative values for traction or braking manoeuvres, respectively. The power delivered by the engine (continuous black line) ranges always in the positive area of the plot. According to the actuated strategy (i.e. pure thermal, hybrid, recharging) the plot indicates the energy flowing to the driveline and/or to the electric motor. The continuous gray line in the figures represents the electrical power from (positive) or to (negative) the batteries during traction or recharging, respectively.

In the suburban transient of Figure 4 all the operating mode are activated. In the interval 220-230 seconds the thermal engine delivers the power for the traction and supplies an extra power to the batteries for recharging. A regenerative braking manoeuvre occurs between 220 and 230 seconds, while the pure electric mode is activated from 230 and 240 seconds. On the other hand the hybrid traction occurs for few seconds during high accelerations at approx 260 and 285 seconds. For the urban transient (Figure 5), the

maximum traction power requested is limited with respect to the suburban transient, thus a major flexibility in the combined use of thermal engine and electrical motor can be achieved. From the figure it emerges the activation of the hybrid mode for most of the transient, while only in few cases pure thermal and pure hybrid traction modes are actuated. These choices are made by the control strategy in order to achieve the highest efficiency in the time interval considered for the dynamic programming optimization, while constraining the battery State Of Charge close to the fixed value of 70%.

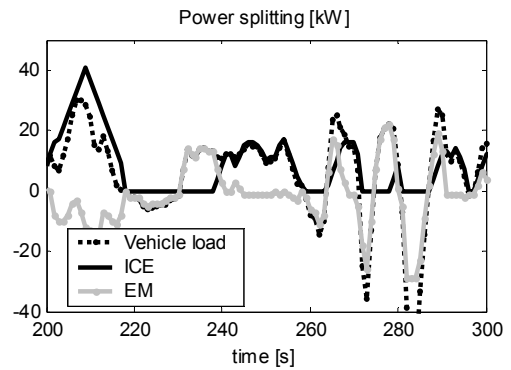

Figure 4 – Power splitting in the suburban route.

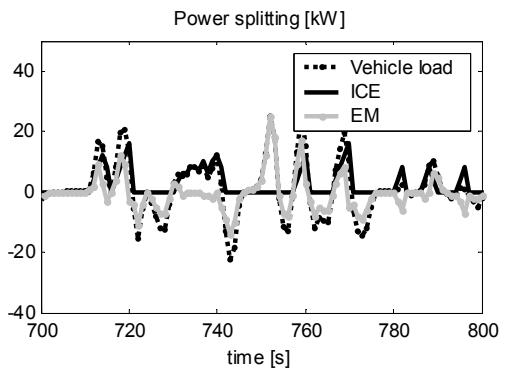

Figure 5 – Power splitting in the urban route.

The battery State Of Charge (SOC) along the transient of Figure 3 is shown in the Figure 6. In the figure a comparison is made between the SOC attained during the test transient, whose power splitting has been described before (see Figure 4 and Figure 5), and the one obtained for a simulation performed on the same transient without the vehicle load prediction. This latter case corresponds to the situation when the load profile is known in advance and the Dynamic Programming optimization is performed without making the load prediction via Time Delay Neural Network (TDNN). Both State Of Charge curves are bounded in a narrow region around the 70% of SOC, thus achieving the charge sustaining batteries operations.

The improvement in fuel economy for HEV due to the recourse to different energy sources (chemical, electrical and mechanical) and the advantages concerned with their optimal management are shown in the Table 1. From the table it emerges that an enhancement of 45% in fuel economy has been achieved with respect the conventional vehicle configuration equipped with the same thermal engine. A

further consideration on the precision achieved with the load prediction model (TDNN) is evidenced in the table. Indeed the fuel economy for the simulation with load prediction (TDNN) and the simulation performed with the advance knowledge of the transient load (Reference) are comparable. This latter result confirms that the proposed method based on a Time Delay Neural Network is suitable for the prediction of the vehicle load. Moreover the precision is consistent with the requirement of on-board Dynamic Programming optimization of the control strategy to achieve the minimum fuel consumption with a battery charge sustaining strategy. These results are encouraging to develop control strategies that account for a prevision of the future system states. Nevertheless, the on-board implementation of optimization technique is not yet feasible because of the computational effort needed.

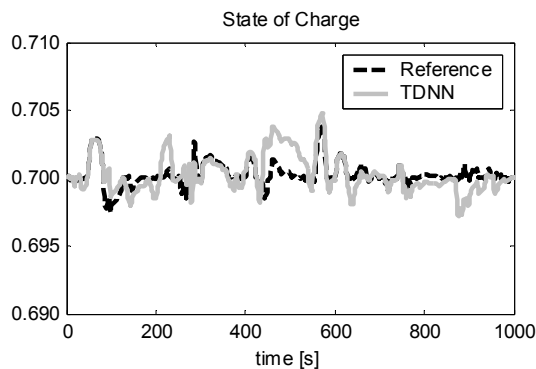

Figure 6 – Battery State of Charge along the test transient of Figure 3. Comparison between the predicted (TDNN) load transient case and the optimal one (reference)

Table 1 – Fuel economy comparison between hybrid and conventional vehicle.

Fuel economy [km/l]		
Hybrid		Conventional
TDNN	Referenc	
16.1	16.8	11.1

CONCLUSIONS

The paper has dealt with the simulation of a parallel Hybrid Electric Vehicle (HEV) and the design of the optimal control strategies. A powertrain model has been used to simulate the dynamic behavior of all the HEV components, making use of different modeling approaches ranging from mean value models (MVM) to fuzzy logic, through neural networks.

An on-board optimization technique based on Dynamic Programming has been implemented to find the control strategy that minimizes the fuel consumption over a time horizon with a battery charge sustaining strategy. Since the Dynamic Programming requires the knowledge of the vehicle load for the actual time horizon, a provisional estimate of the load has been considered through the implementation of a Time Delay Neural Network.

The results obtained for a real drive schedule show a satisfactory level of precision achievable with the load prediction model which allows to optimize the control strategies. The fuel economy has been improved of 45% with respect to a conventional vehicle with the same thermal engine.

ACKNOWLEDGMENTS

The present research is supported by University of Salerno (Project ex 60% 2001). The doctoral fellowship of Marco Sorrentino is granted by Centro Ricerche Fiat (Italy).

REFERENCES

Arsie I., Pianese C., Rizzo G., Flora R., Serra G. (2000), *A Computer Code for S.I. Engine Control and Powertrain Simulation*, SAE Paper 2000-01-0938, in SAE 2000 Transactions - Journal of Engines, Vol. 109-3.

Arsie I., Pianese C., Rizzo G., Santoro M., (2002-I) - *Optimal Energy Management in a Parallel Hybrid Vehicle*, 6th ASME-ESDA Conference, Turkey, July 8-11, 2002.

Arsie, I., Pianese, C., and Sorrentino, M., (2002-II) - *Recurrent Neural Network Based Air-Fuel Ratio Observer for SI Internal Combustion Engines*, 6th ASME-ESDA Conference, Turkey, July 8-11, 2002.

Babuška R. (1998), *Fuzzy Modeling for Control*, Kluwer Academic.

Baumann B., Rizzoni G. and Washington G. (1998), *Intelligent Control of Hybrid Vehicles using Neural Networks and Fuzzy Logic*, SAE paper 981061.

Bellmann R. (1957), *Dynamic Programming*, Princeton University Press.

Brahma A., Guezennec Y., Rizzoni G., (2000), *Dynamic optimization of mechanical/electrical power flow in parallel hybrid electric vehicles*, AVEC 2000, 5th Int. Symp. on Adv. Veh. Control, Ann Arbor, Aug. 2000.

Burch S., Cuddy M., Johnson V., Markel T., Rausen D., Sprik S., Wipke K. (1999), *ADVISOR: Advanced Vehicle Simulator*, available at: <http://www.ctts.nrel.gov/>.

Guzzella L. and Amstutz A. (1999), *CAE Tools for Quasi-Static Modeling and Optimization of Hybrid Powertrains*, IEEE Transactions on Vehicular Technology, vol. 48, no. 6, November 1999.

Haykin, S., (1999) - *Neural Networks*, Prentice Hall.

Hochgraf C.G., Ryan M.J., Wiegman H. (1996), *Engine Control Strategy for a Series Hybrid Electric Vehicle Incorporating Load-Leveling and Computer Controlled Energy Management*, SAE Paper 960230.

Kang J.M., Kolmanovsky I., Grizzle J.W. (2001), *Dynamic Optimization of Lean Burn Engine Aftertreatment*, Journal of Dynamic Systems, Measurement, and Control, June 2001, Vol. 123 pp. 153-160

Nagasaka A., Nada M., Hamada H., Hiramatsu S., Kikuchi Y., Kato H. (1998), *Development of the Hybrid/Battery ECU for the Toyota Hybrid System*, SAE Paper 981122.

Patterson, D. W., (1995) - *Artificial Neural Networks – Theory and Applications*, Prentice Hall.

Powell B.K., Bailey K.E., Cikanek S.R. (1998), *Dynamic modeling and Control of Hybrid Vehicle Powertrain Systems*, IEEE Transactions on Control Systems, vol. 18, no. 5, October 1998.

Riley Q. R. (1994), *Alternative Cars in the 21st Century: A New Personal Transportation Paradigm*, SAE Publication.